

SPHERE MINIATURE

DO3-51-3080-SH6T-V200203

Page 1/1

SH6T
Code 3080

DESCRIPTION

- Sobres et esthétiques
- Enceintes closes ABS de forme sphérique
- Haut parleur bi-cône large bande à membrane siliconée
- Transformateur imprégné
- Fixation par étrier livré



SPECIFICATIONS TECHNIQUES

Puissance Nominal (100V)	Watts	6
Puissance Maximum	Watts	10
Domaine utile des Fréquences	Hertz	150-20000
Pression Acoustique 1w (Totale)/1m dB		88-(96)
Connexion		Cable 4 fils
Sélecteur de puissance	Watts	6/3/1,5
Impédances	Ohms	1,7/3,3/6,7K
Dimensions emballage: LxHxP	mm	135x160x135
Poids avec emballage	Kg	0,742

SCHEMA

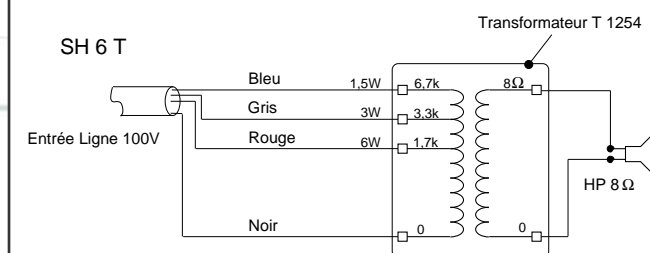

DIMENSIONS

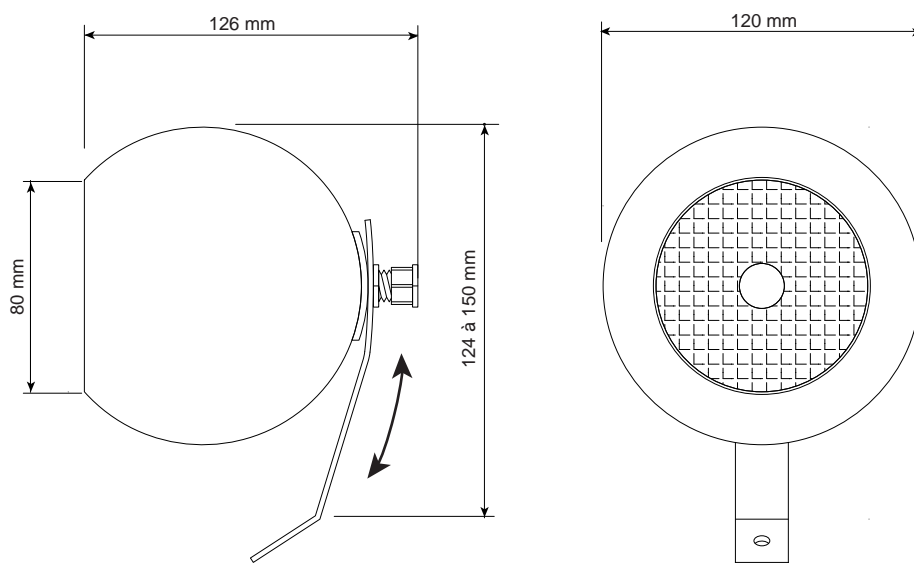

SPECIFICATIONS SUBJECT TO MODIFICATIONS

DOCUMENT NON CONTRACTUEL

Système de management certifié



MERLAUD

9 rue de La Briqueterie - P.A.E. des FAUVETTES - 95330 DOMONT (FRANCE)

Tel. 01 39 91 77 78 - Fax 01 39 91 90 66 - www.merlaud.com - merlaud@merlaud.com

DO3-51 FT NT V040412

MINIATURE SPHERE

DO3-51-3080-SH6T-V200203

Page 1/1

DESCRIPTION

- Aesthetic with high performance spherical speaker.
- Moulded white colour ABS. Other colours on request.
- Dual cones wide band silicon treated speaker.
- Impregnated low insertion loss multi-taps transformer.
- With L bracket mounting.



TECHNICAL SPECIFICATIONS

Nominal Power (100V)	Watts	6
Maximum Power	Watts	10
Frequency response	Hertz	150-20000
SPL (max) 1W@1m	dB	88-(96)
Connection	4 Wires cable	
Power Selector (100V)	Watts	6/3/1,5
Impédances	Ohms	1,7/3,3/6,7K
Pack dimensions : WxHxD	mm	135x160x135
Pack Weight	Kg	0,742

WIRING

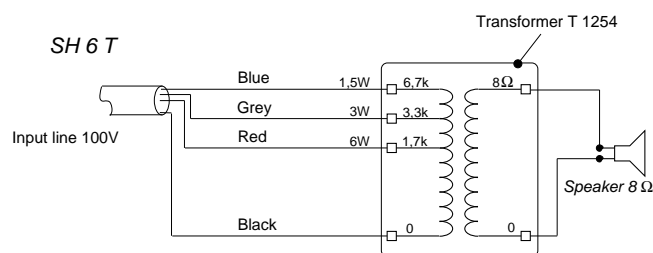

DIMENSIONS

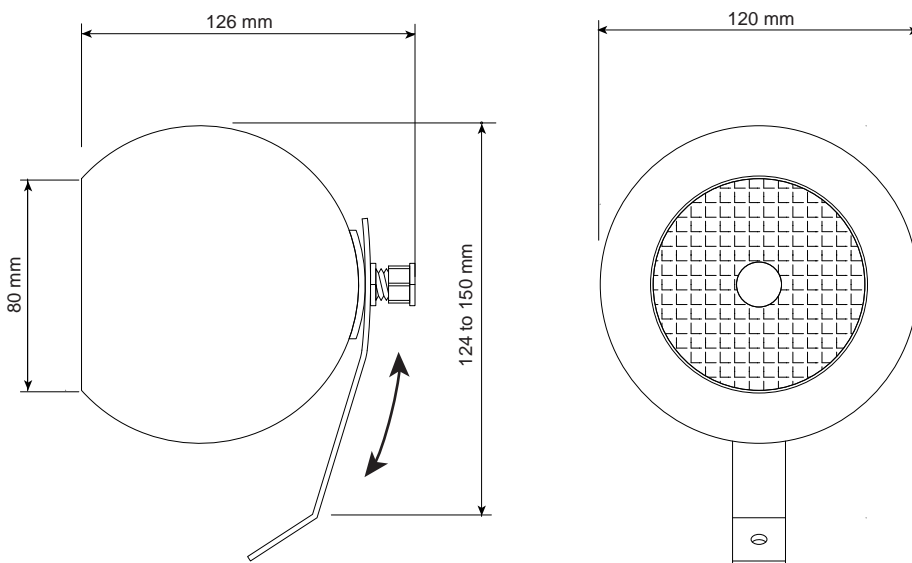

SPECIFICATIONS SUBJECT TO MODIFICATIONS

DOCUMENT NON CONTRACTUEL